

HZJF-9011D
Partial Discharge Detector

User Manual

Dear user:

Thank you for choosing HZJF-9011D Partial Discharge Detector.

We hope that this instrument can make your work easier and more enjoyable, so that you can get the feeling of office automation in the test and analysis work.

Before using the instrument, please read this manual, and operate and maintain the instrument according to the manual to prolong its service life. "Just a light press, the test will be completed automatically" is the operating characteristics of this instrument.

If you are satisfied with this instrument, please tell your colleagues; if you are not satisfied with this instrument, please call (0312) 6775656 to tell you to serve you at all times-Baoding Huazheng Electric Manufacturing Co., Ltd., our company will definitely make you satisfied !

Contents

I.Overview.....	1
II.Main Technical Indicators.....	1
III.Operating Principle.....	3
IV.Structure Description.....	5
V.HZJF-9011D Description Of Front Panel And Rear Panel Components.....	6
VI.Operating Instructions.....	6
VII.Packing list.....	24
VIII.User selected equipment (Optional need extra money)	24

I.Overview

HZJF-9011D partial discharge detector is a new type of digital partial discharge detector developed by our company. It retains the advantages of JF-A01N partial discharge detector, reduces the volume and optimizes the performance. It uses 10.1 inch touch screen to replace the traditional operation mode of oscillograph and physical knob, making it more convenient to use.

The instrument adopts full touch screen operation, which not only improves the service life of the operation, but also has the following functions: one key automatic correction; high voltage test voltage divider ratio can be set; serial communication upload test data. The instrument has the characteristics of high sensitivity, wide application range, wide dynamic range of amplification system, multiple frequency band combinations (nine kinds), and strong anti-interference ability. It is a practical partial discharge testing instrument widely used by electric power departments, manufacturers and scientific research institutes.

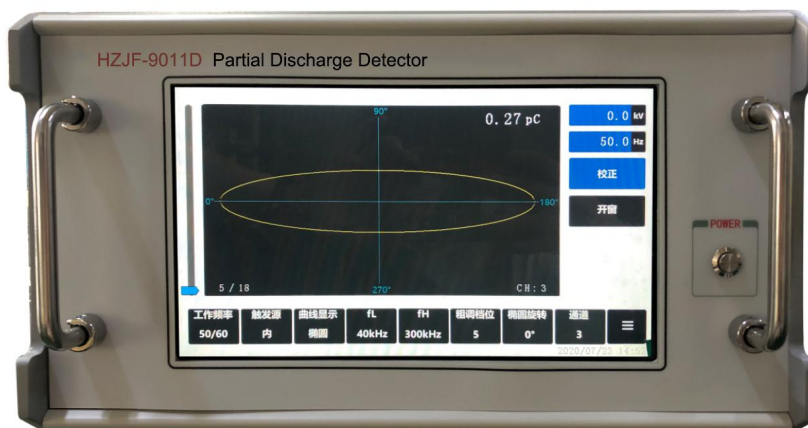

II.Main Technical Indicators

1. The equivalent capacitance ranges from 6pF to 250 μ F
2. Number of channels: single channel
3. Measurement range: 0.1pc-10000nc
4. Detection sensitivity and allowable current (see Table 1)

NO.	Tuning Capacitance Range	Sensitivity (PC) (Unbalance d Circuit)	Effective Value Of Allowable Current	
			Unbalanced Circuit	Balance Circuit
1	0 ~ 25 ~ 100pF	0.02	30mA	0.25A
2	25 ~ 100 ~ 400pF	0.04	50mA	0.5A
3	100 ~ 400 ~ 1500pF	0.06	120mA	1A
4	400 ~ 1500 ~ 6000pF	0.1	0.25A	2A
5	1500 ~ 6000 ~ 25000pF	0.2	0.5A	4A
6	0.006 ~ 0.025 ~ 0.1μF	0.3	1A	8A
7	0.025 ~ 0.1 ~ 0.4μF	0.5	2A	15A
8	0.1 ~ 0.4 ~ 1.5μF	1	4A	30A
9	0.4 ~ 1.5 ~ 6.0μF	1.5	8A	60A
10	1.5 ~ 6.0 ~ 25μF	2.5	15A	120A
11	6.0 ~ 25 ~ 60μF	5	25A	200A
12	25 ~ 60 ~ 250μF	10	50A	300A
7R	Resistance	0.5	2A	15A

Table 1. Detection sensitivity and allowable current value of input unit

5. Elliptic scan time base

- (1) Frequency 50/60, 100, 150, 200, 400Hz
- (2) Rotation: 30 ° as the first gear, and can rotate 120 °
- (3) Working method: ellipse sine wave straight line

6. Display unit

10.1 inch capacitive touch screen is used.

7. Amplifier

- (1) 3dB low frequency fl:10, 20, 40KHz optional
- (2) 3dB high frequency fh:80, 200, 300kHz optional

(3) Gain adjustment, rough adjustment 6, inter gear gain difference 20 ± 1 dB, fine adjustment range >20db

(4) Asymmetry of positive and negative pulse response < 1 dB

8. Time window

(1) Window width: adjustable, $5^\circ \sim 170^\circ$ at 50Hz

(2) Window position: each window can rotate $0^\circ \sim 170^\circ$

(3) Two time windows can be opened separately or simultaneously.

9. Peak pulse display

The touch screen displays 1 decimal place (10pc or more), 2 decimal places (less than 10pc), error: $\pm 3\%$ (in full scale)

10. Test voltage display

(1) Range 150kV

(2) Input impedance: $>1\text{m}\ \Omega$

(3) Display: touch screen display, display 1 decimal place

(4) Error: $\pm 1\%$

11. Test frequency display

Error: less than $\pm 1\%$

12. Zero standard system

Zero sign is consistent with all ellipse scanning frequencies

13. Structure

(1) Dimensions: 370mm (width), 460mm (depth), 215mm (height)

(2) Weight: about 12.5kg

III. Operating Principle

When the sample C_x produces partial discharge under the test voltage, the pulse current is generated through the coupling capacitor C_k , and the pulse signal is picked up by the input unit. After being amplified by low noise preamplifier, filter amplifier and main amplifier (reaching the required amplitude), the visible discharge pulse is generated on the elliptical scanning baseline of the touch screen, and the pulse peak value is displayed

IV. Structure Description

The instrument is a desktop standard cabinet structure. The operation surface of the instrument is divided into two parts: front panel and back panel. The positions of each component are shown in Fig. 2a and 2b

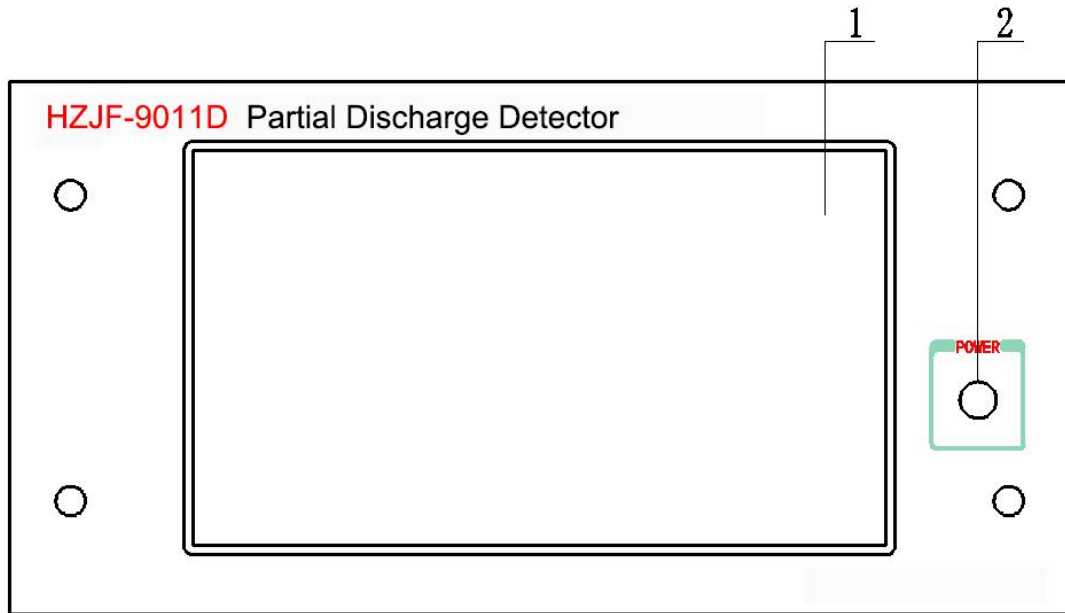

Figure 2a HZJF-9011D Schematic diagram of front panel of partial discharge detector

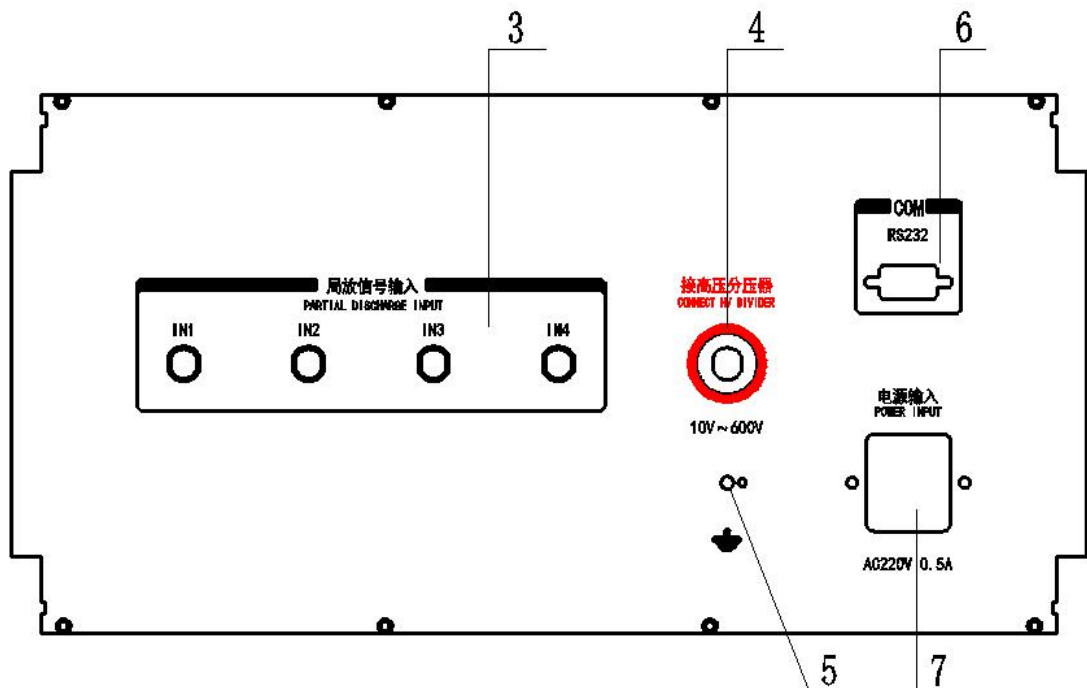

Figure 2b HZJF-9011D Schematic diagram of back panel of partial discharge detector

V.HZJF-9011D Description Of Front Panel And Rear

Panel Components

1. Touch screen: display the measured PD waveform, PD, test voltage, test frequency and other parameters;
2. Power switch button: press once to turn on; press again to turn off;
3. Partial discharge input: partial discharge measurement signal input, HZJF-9011D single channel, signal can be connected from any channel;
4. High voltage voltage divider, voltage range: 150V;
5. Grounding bolt: reliable grounding is required during test;
6. RS232 port: through this serial port, the parameters of partial discharge instrument can be uploaded to other equipment;
7. External power supply input;

VI.Operating Instructions

(1) Preparation test

1. Check the grounding condition of the test site. Connect the grounding bolt 5 at the back of the instrument with the grounding wire of the test site with thick copper wire (preferably braided copper tape). The grounding short circuit piece of the input unit should also be properly grounded.
2. According to the size of the test capacitor CX coupling capacitance CK, select the suitable serial number input unit. In Table 1, the tuning capacitance refers to the equivalent capacitance seen at the two ends of the primary winding of the input unit (which can be roughly estimated by the series value of CX and CK).
The input unit should be as close as possible to the tested object. The Q9 socket of the input unit is connected to the amplifier input socket 3 (channel 1) on the back panel of the instrument through an 8-meter long cable.
3. There are several methods to connect the sample to the input unit (see Figure 3).

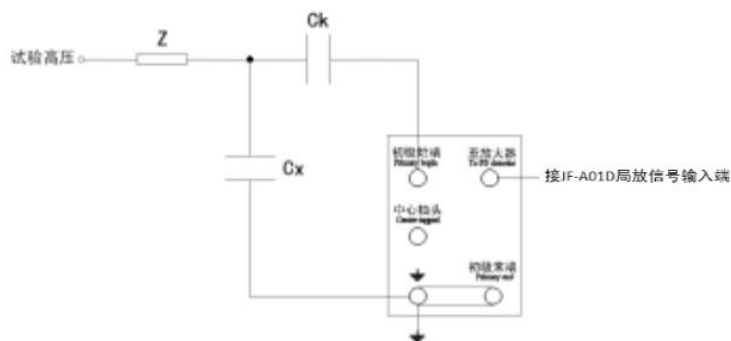

Figure 3a Parallel connection

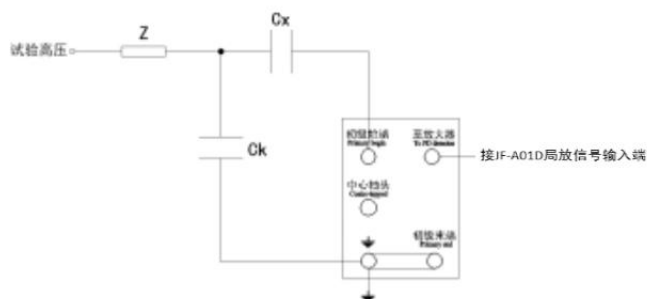

Figure 3b Series connection

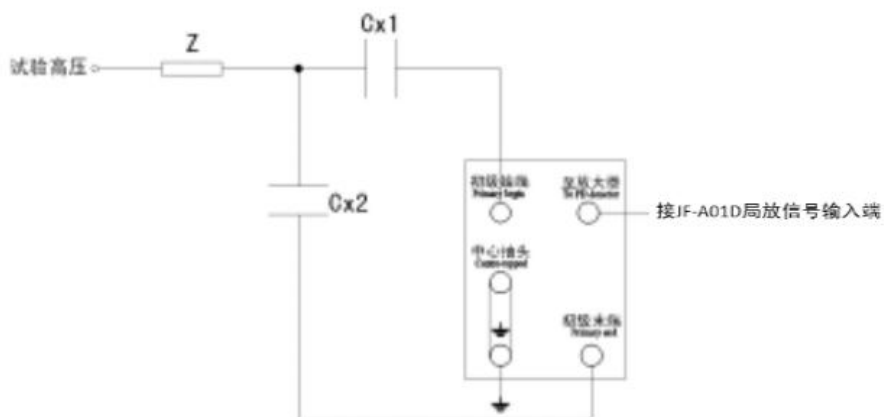

Figure 3c Balanced connection

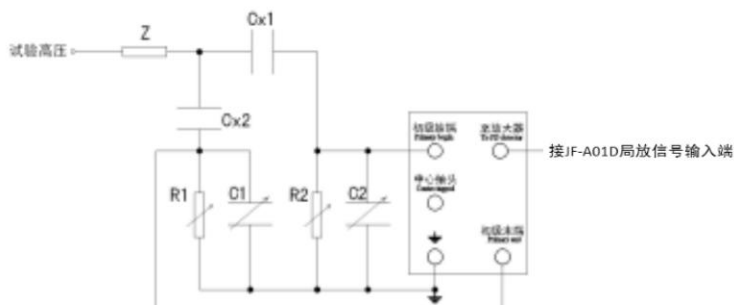

Figure 3d Bridge tapping method

In the figure: CX -- sample; CK -- coupling capacitance; Z -- blocking impedance;

R1, C1, R2 and C2 are the balanced regulating impedances.

4. Connect the resistance voltage divider or capacitor voltage divider at the high voltage end, and connect its output to the input socket 4 of back plate "connected to high voltage voltage divider" through the measuring cable.

5. The common partial discharge test circuit is shown in Figure 4

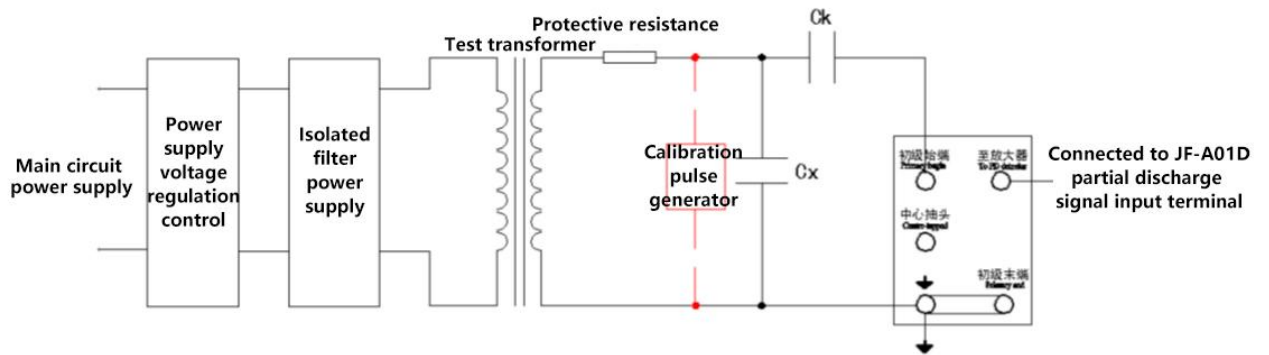
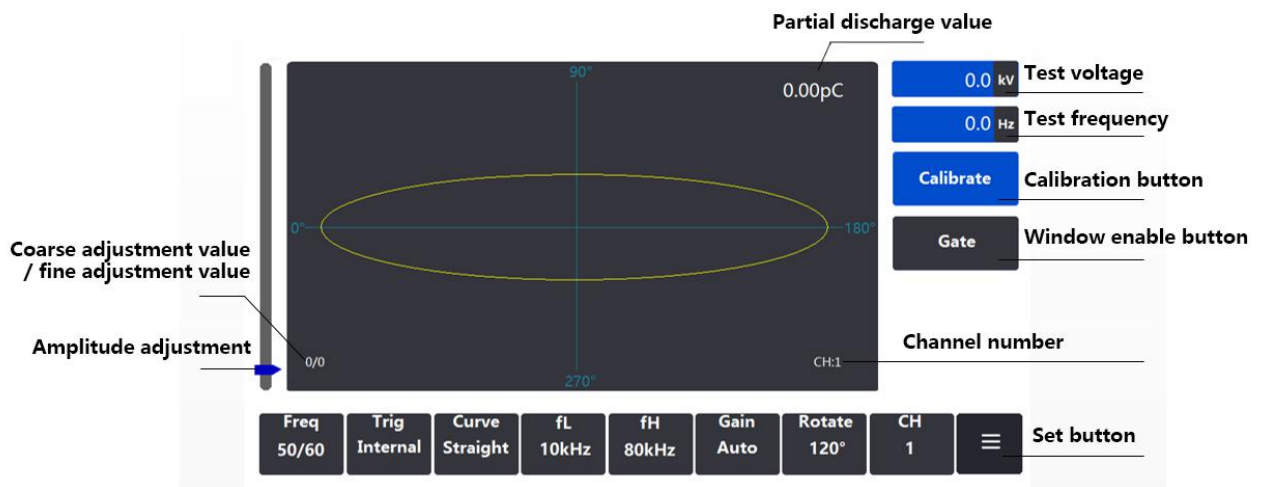

Figure 4 Standard connection circuit of partial discharge test (parallel connection of direct method)

(2) How to use it



Home Screen

Window opening position / window length

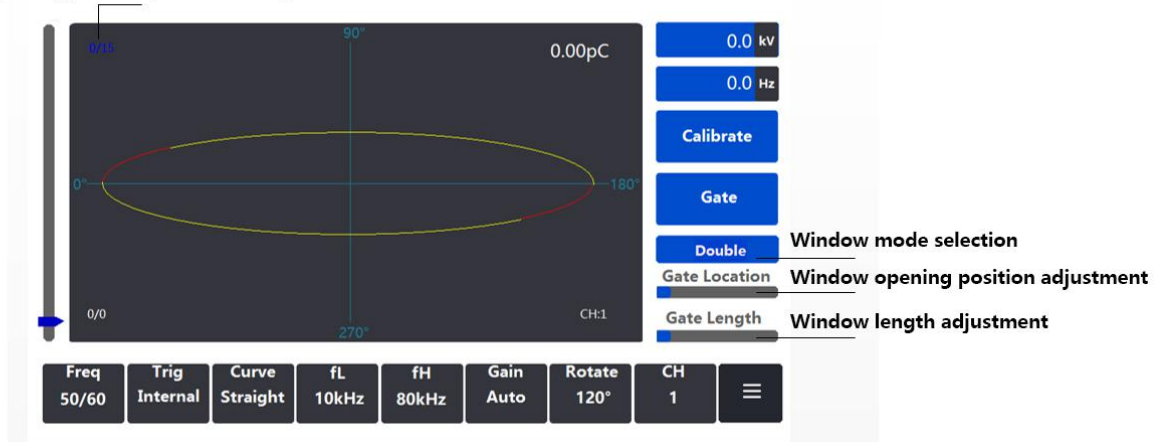

Windowing interface

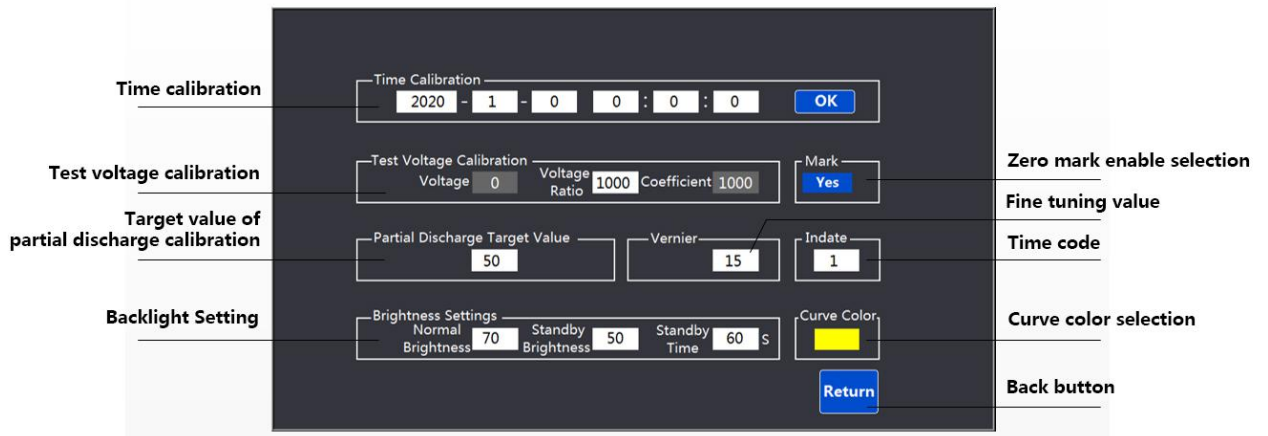

Setting interface

Example 1: adjust the working frequency.

Step 1: click the working frequency button.

Step 2: select the corresponding working frequency in the pop-up menu.

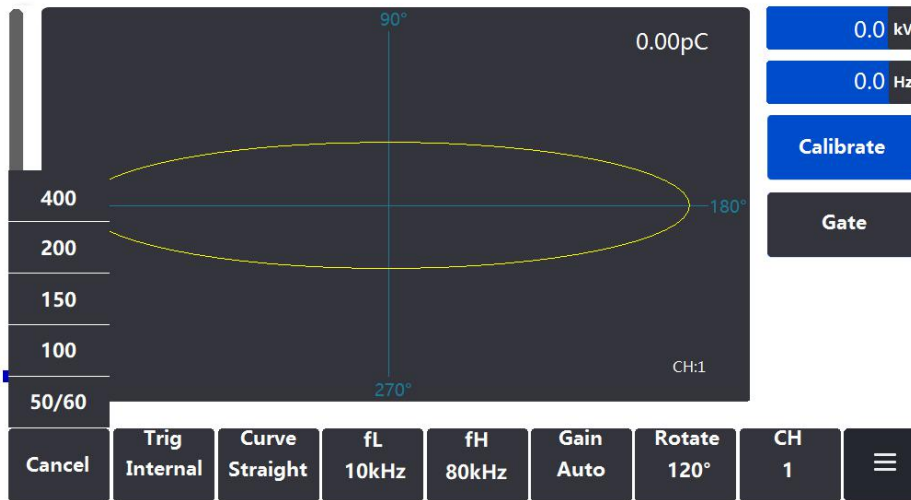

Example 2: select the curve display mode.

Step 1: click the curve display button.

Step 2: select the corresponding display mode in the pop-up menu.

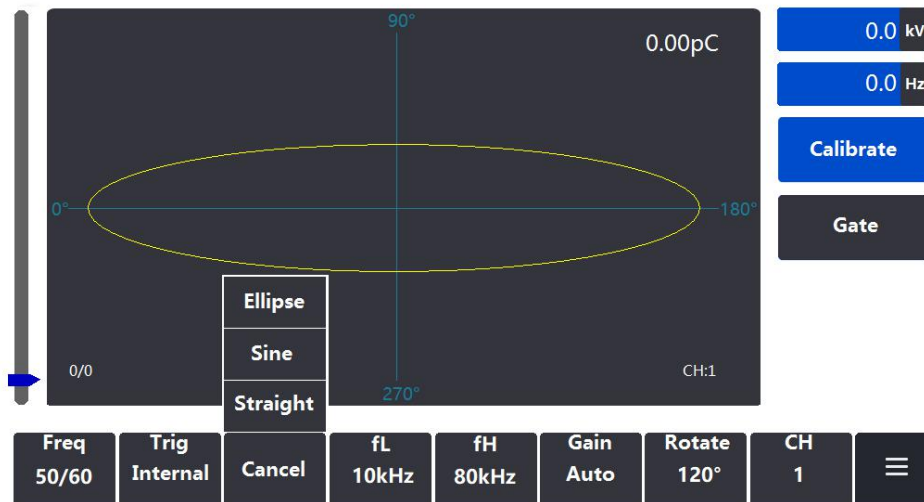

Example 3: setting coarse adjustment gear.

Step 1: click the coarse adjustment gear button.

Step 2: select the corresponding gear in the pop-up menu.

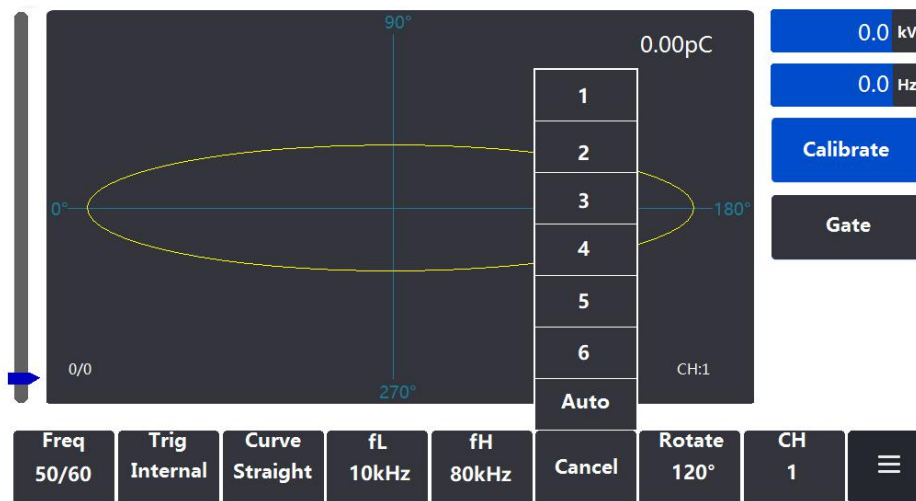

Example 4: select signal channel.

Step 1: click the channel button.

Step 2: select the corresponding channel in the pop-up menu.

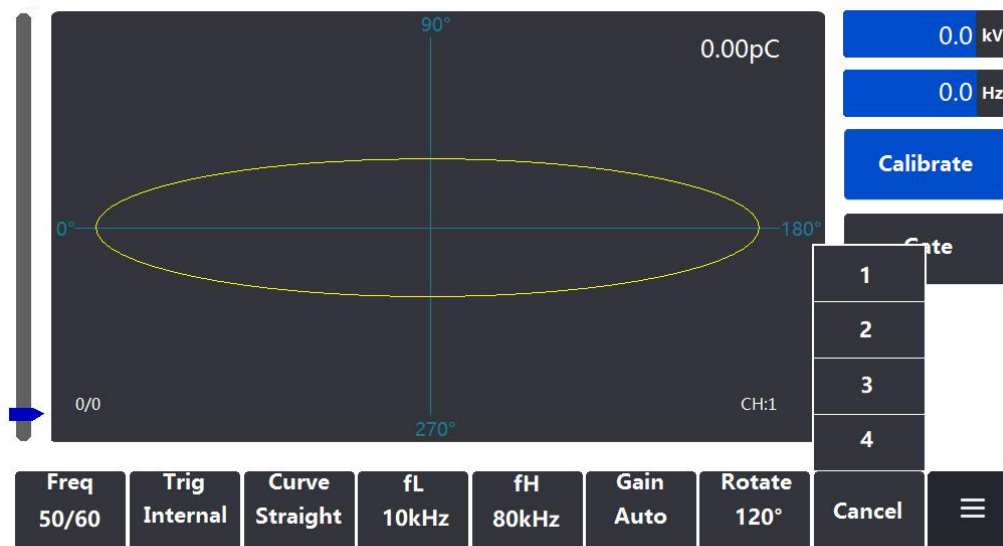

Example 5: window operation.

Step 1: click the window opening button to enable the window opening function.

Step 2: click the window mode button to select the corresponding selection mode.

Step 3: adjust the corresponding window opening area through the window position slider and window length slider.

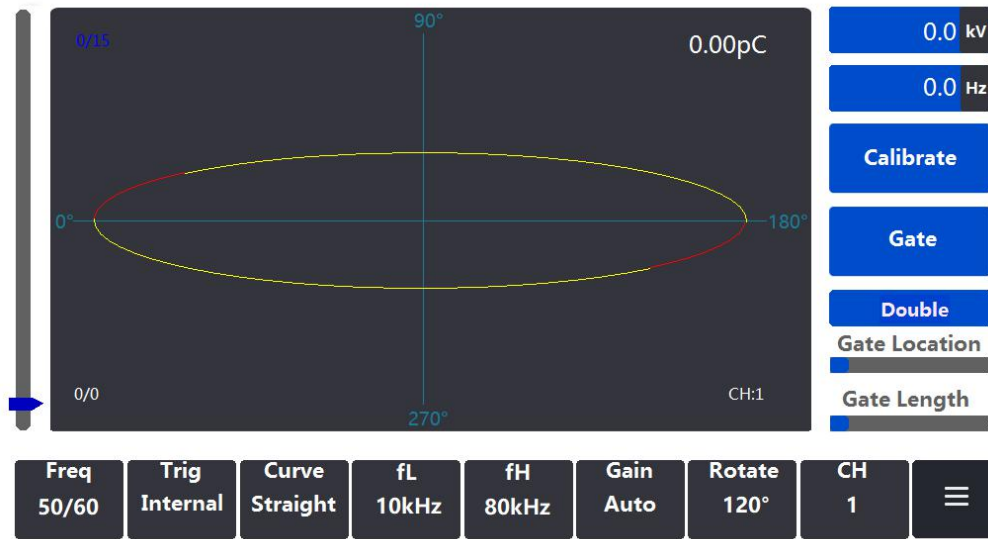

Example 6: setting interface operation.

Step 1: click the setting button to switch to the setting interface.

Step 2: click the value box to be set and the keyboard input window will pop up.

Step 3: after inputting the corresponding value in the keyboard window, click the input completion button.

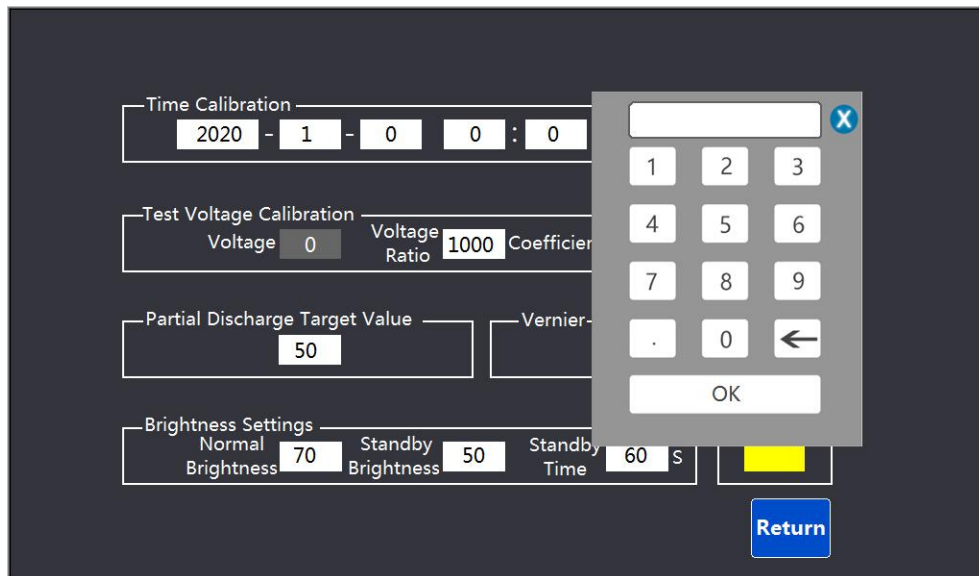

1. Start up preparation

Connect the power socket 7 with the 220 V power frequency power supply, press the power switch 2 to start the machine, select "50 / 60" in the "working frequency" button

menu and "ellipse" in the display mode button menu. Confirm the set PD calibration target value (factory default 50pc).

2. Instrument calibration

Refer to figure 4, connect the wire and calibrate it with JZF calibration pulse generator before adding test voltage.

Note: the lead wire on the red terminal of the calibration pulse generator shall be as short as possible and connected to the high-voltage end of the test object, and the black terminal wire shall be connected to the low-voltage end of the test object.

Press the high frequency button "FH" and the low frequency button "FL" to select the appropriate frequency bandwidth.

Press the "coarse adjustment" button, select the automatic gear, and then press the "correction" button; the discharge quantity indication is consistent with the known electric quantity injected.

After the calibration is completed and before the test voltage is applied, the connection line between the calibration pulse generator and the test object must be disconnected to prevent the high voltage from damaging the calibration pulse generator.

3. Test operation

Turn on the power supply of high-voltage test circuit, slowly increase the test voltage, press the "ellipse rotation" button, select the rotation angle, and make the ellipse turn to the expected place which is most convenient for observation during discharge. Usually, this position is the place where the zero mark pulse is located on the left side of the upper part of the ellipse and the right side of the lower part respectively. When the voltage is increased continuously, pay attention to the first continuous discharge. When the discharge exceeds the specified minimum value, the voltage is the starting voltage of partial discharge.

Various interferences are often found in the test. The width and position of the red area on the ellipse can be changed by "windowing mode", "windowing position" and "windowing length" to avoid the interference pulse.

4. Partial discharge test with frequency higher than 50 Hz

When partial discharge test higher than 50 Hz is required, press the "working frequency" button to select the corresponding frequency range, and take 10v-250v test voltage from high frequency test power supply and send it to socket 4.

(3) Supplementary Provisions

1. Identification of discharge type and discharge source

Firstly, the ellipse track on the oscillograph screen is introduced. It rotates clockwise. The positive zero mark pulse indicates that the test voltage begins to change from negative to positive; on the contrary, the midpoint between the two zero standards is the positive and negative peak positions of the test voltage.

It is a highly technical and practical knowledge to identify discharge types and various interferences from discharge patterns on ellipses (it is better to combine with other methods to confirm). CIGRE (International Conference on large power grid) has also compiled a pamphlet for recognizing the discharge pattern. It is judged according to the discharge position and movement in the discharge pattern, the consistent degree of discharge amplitude in positive and negative half cycle, and the variation characteristics of discharge amplitude with test voltage and pressurization time, which can only be roughly introduced here.

Generally speaking, the main characteristic of partial discharge, which is regarded as the formation of real internal bubble, is that most of the partial discharge occurs within two and a half weeks near the rising position of the test voltage peak.

(1) Typical internal bubble partial discharge (see Figure 5), waveform characteristics: a discharge is mainly shown in the test voltage from zero to peak within two elliptical phase limits. B when the initial voltage U_I , the discharge usually occurs near the peak value. When the test voltage exceeds U_I , the discharge extends to the zero position. C the discharge times and amplitudes of the two opposite half cycles are approximately the same (the maximum difference is 3:1). The discharge waveform can be distinguished. There are several situations: 1) if the discharge amplitude increases with the increase of

test voltage, and the discharge waveform becomes indistinct, it is often that there are many bubbles in the dielectric or discharge on the surface of the dielectric; 2) in addition to the above conditions, if the discharge amplitude increases rapidly with the pressure time (up to 100 times or more), it is often the bubble in the insulating liquid Discharge, a typical example is the discharge of oil impregnated paper capacitor.

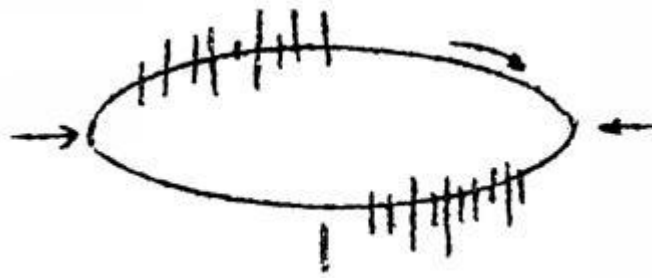

Figure 5

(2) For the discharge of bubbles between metal and dielectric (see Fig. 6a), the waveform characteristics are as follows: there are many discharges with small amplitude in the positive half cycle and a few discharges with large amplitude in the negative half cycle, and the amplitude difference can reach 10:1. Others are the same as above. A typical example is the discharge of polyethylene cable with poor adhesion between insulation and conductor. If the discharge amplitude increases with the increase of the test voltage, and the discharge waveform becomes fuzzy, it often contains multiple bubbles of different sizes, or the discharge occurs between the exposed metal and the dielectric surface (see Fig. 6b).

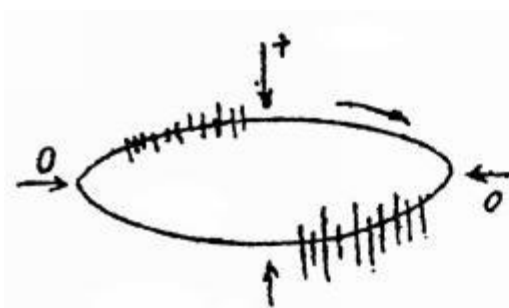

Fig 6a

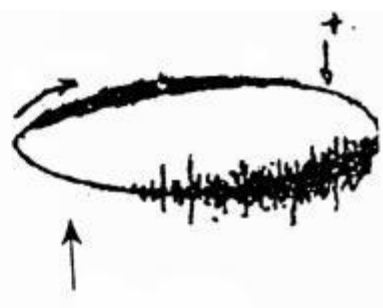

Fig 6b

Some cases which are mainly considered as interference or abnormal discharge are

discussed below.

(3) Suspended potential object discharge (see Fig. 7a), waveform characteristics: it appears in two quadrants of positive and negative half cycle before the voltage peak, the amplitude, pulse number and position are the same, sometimes (as shown in Fig. 7b) appear in pairs, the discharge can move, but the mutual interval between them remains unchanged, when the voltage increases, the number of elements increases, the interval decreases, but the amplitude remains unchanged, and sometimes the voltage rises to a certain value Will disappear, but will reappear at this value. Cause: discharge caused by the gap between metals. The gap may be between two independent metal bodies on the ground or in the sample, such as loose shielding.

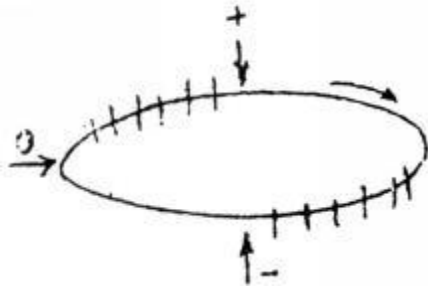

Fig. 7a

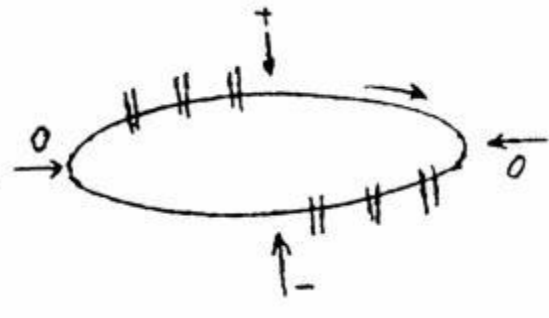

Fig. 7b

(4) External tip corona (see Figure 8a), waveform characteristics: the initial discharge only occurs in one and a half cycles of the test voltage, and is symmetrically distributed on both sides of the peak value. When the test voltage increases, the number of discharge pulses increases sharply, but the amplitude remains unchanged and extends to both sides (as shown in Fig. 8b). Cause: high voltage tip or edge discharge in air. If the discharge occurs in the negative half cycle, it indicates that the tip is at high voltage; if the discharge occurs in the positive half cycle, the tip is at the ground potential.

1.

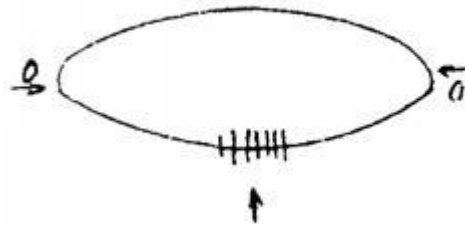

Fig. 8a

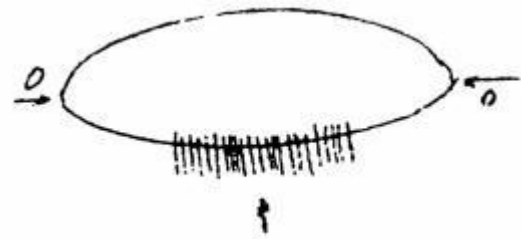

Fig. 8b

(5) Tip corona in liquid medium (Fig. 9a), waveform characteristics: discharge occurs in two and a half cycles, symmetrically distributed in two voltage peaks. Each group of discharge is equal interval, but a group of larger amplitude discharge appears first, and increases with the increase of test voltage, not necessarily equal amplitude: a group of small amplitude discharge amplitude is equal, and does not change with voltage (as shown in Fig. 9b). Cause: the tip or edge discharge in insulating liquid, if a group of large discharge occurs in positive half cycle, the tip is at high voltage; if it appears in negative half cycle, the tip is at ground potential.

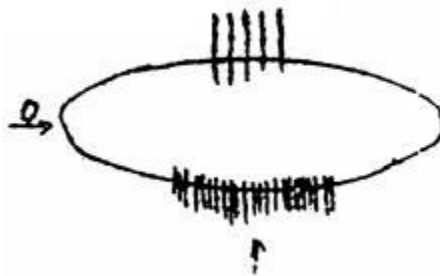

Fig. 9a

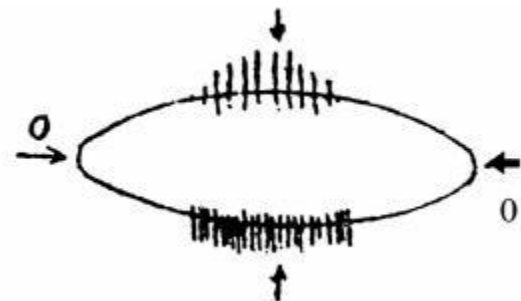

Fig. 9b

(6) Poor contact (FIG. 10), waveform characteristics: symmetrically distributed on both sides of the zero point of the test voltage, the amplitude is roughly unchanged, but it drops to zero near the peak value of the test voltage, and the waveform is rough and unclear. When the voltage increases, the amplitude increases slowly, and sometimes it disappears completely when the voltage reaches a certain value. Causes: the connection point of metal to metal poor contact in the test circuit; the poor contact of semiconductor particles in the shielding layer of plastic cable; the plug piece of aluminum foil of capacitor, etc. (the capacitor can be charged and then short circuited to eliminate).

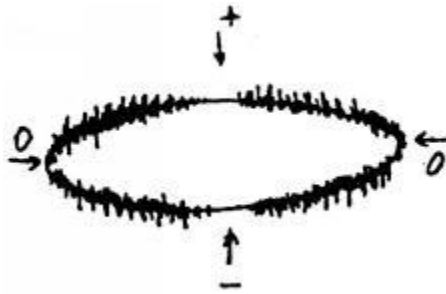

Fig. 9

(7) Thyristor element (Fig. 11a), waveform characteristics: fixed position, each element generates an independent signal. When the circuit is connected and the electromagnetic coupling effect is enhanced, the signal amplitude increases. During the voltage regulation test, the pulse signal will generate high frequency waveform broadening, thus increasing the space occupation (Fig. 11b). The reason is that there are silicon controlled elements nearby in operation.

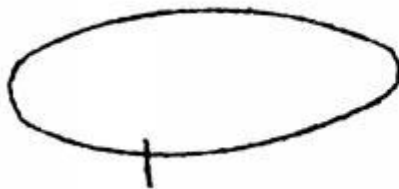

Fig. 11a

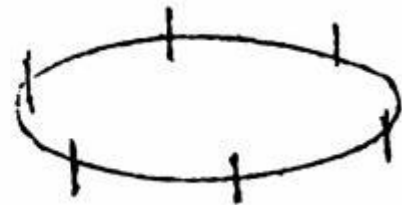

Fig. 11b

(8) Relay, contactor, glow tube and other actions (Fig. 12), waveform characteristics: irregular or intermittent waveform,

It has nothing to do with the test voltage. Cause: thermal relay, contactor, spark tester and recorder with spark discharge act.



Fig. 12

(9) Induction motor (Fig. 13), waveform characteristics: two symmetrical clusters of

signals appear in the positive and negative half cycle, and rotate at a constant speed in reverse direction along the elliptic time base. Cause: asynchronous motor running signal coupled to the detection circuit.



Fig. 13

(10) Fluorescent lamp (Fig. 14), waveform characteristics: fence like, pulse with the same amplitude, with two clusters of pulse groups symmetrically appearing in positive and negative half waves. Reason: fluorescent lamp lighting.

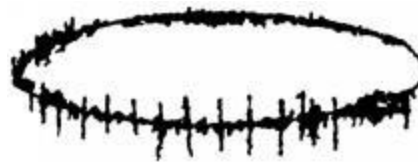

Fig. 14

(11) Waveform characteristics of radio interference (Fig. 15a, FIG. 15b): high frequency sine wave with amplitude modulation, independent of test voltage. Reasons: wireless telephone, broadcast telephone, carrier communication, etc.

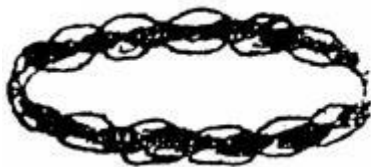

Fig. 15a



Fig. 15b

(12) Motor interference (Figure 16), waveform characteristics: discharge waveform is uniformly announced along the elliptic baseline, and each single group number is in the shape of "hill".

Cause: motor with commutator, such as fan, hair dryer operation interference.

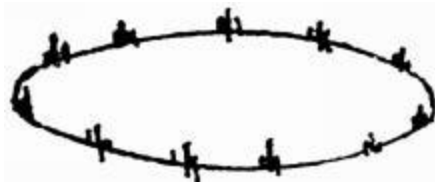

Fig. 16

(12) Medium and high frequency industrial equipment (Figure 17), waveform characteristics: continuous occurrence, only within half a cycle of power waveform. Cause: induction heating device and ultrasonic generator with frequency close to detection frequency, etc.



Figure 17

(14) Core magnetic saturation harmonic (Fig. 18), waveform characteristics: lower frequency harmonic oscillation, appeared in two and a half cycles. The amplitude increases with the increase of voltage and disappears without voltage. Cause: resonance caused by magnetic saturation of various iron core equipment (test transformer, filter reactor, isolation transformer, etc.) of the test system.



Fig. 18

(15) The electrode moves mechanically in the direction of the electric field (Fig. 19). The waveform characteristics are: only two discharge responses symmetrical to the peak value appear on the half cycle (positive or negative) of the test voltage, with the same amplitude but opposite pulse direction. At the initial voltage, the two pulses are close to each other at the peak, and gradually separate when the voltage increases, and a new

pulse signal pair may be generated. Reason: part of the electrode (especially the metal foil electrode) moves under the action of an electric field.



Fig. 19

(16) The waveform characteristics of leakage trace and branch discharge: the discharge signal waveform does not conform to the general typical image, and the waveform is irregular and uncertain. Cause: electric leakage on the polluted insulation or carbonization trace or branch passage caused by partial overheating of insulation. In the discharge test, it is necessary to ensure that other components (test transformer, blocking coil, coupling capacitor, high-voltage resistance, etc.) in the test circuit will not discharge. The common method is to replace the sample test with a non discharge capacitor or insulation structure of the same order of magnitude as the sample capacitance to see if there is discharge.

After understanding the waveform characteristics and sources of various discharge types and identifying the interference, measures can be taken to eliminate the interference causes and correctly conduct discharge measurement according to the specific situation.

2. The main formation and invasion ways of interference

(1) The main forms of interference are: ① interference from power supply network; ② interference from grounding system; ③ interference received by other high-voltage tests or electromagnetic radiation field; ④ interference generated by test circuit itself; ⑤ interference caused by poor contact in test circuit or sample.

(2) There are usually several ways of interference invasion: ① capacitance coupling: if there is interference voltage on the conductor (such as feeder), the stray capacitance of the conductor to the test circuit can be coupled to the test circuit. Capacitive coupling is most likely to occur when the capacitance of the sample is small; ② inductive coupling: if the conductor (such as the feeder) carries interference current, it is coupled to the test

circuit through the magnetic induction between it and the test circuit. In the measurement of large capacitance test object, as long as there is a small mutual inductance m , the inductive coupling effect is very strong; ③ grounding coupling: This is mainly caused by multi-point grounding, and the current flows through two grounding points in the grounding system, thus establishing an interference voltage in the test circuit; ④ coupling through high-voltage power supply: the interference voltage from the power grid main line passes through the primary and secondary windings of the test transformer. The capacitance coupling between them enters the test circuit.

3. Main measures to eliminate or restrain interference

(1) A filter control power supply (such as LB-5) with voltage regulator, isolation transformer and filter is adopted. The primary winding of the isolation transformer is shielded to the ground of the power grid system; the secondary winding is shielded to the ground of the test circuit (or the ground of the fully shielded system).

(2) Set up shielding room. Only the test circuit part can be shielded, while the high voltage transformer is outside, and the high voltage is introduced by bushing (but filter must be used). High voltage power supply can also be placed in the shielding room, while the partial discharge detector is outside. It is better to put the detector in the shielding room. The purpose and function of shielding room is to prevent capacitive coupling and inductive coupling. For the design of shielding room, please refer to relevant information.

(3) For reliable single point grounding, the test loop system or the whole shield body shall be designed as single point grounding structure, and the grounding resistance shall be small. The grounding point shall be separated from the ground grid and power grid neutral line of general laboratory. As shown in Fig. 20a, it is a single point grounding, while the grounding mode in Fig. 20b is easy to form loop ground current and cause interference.

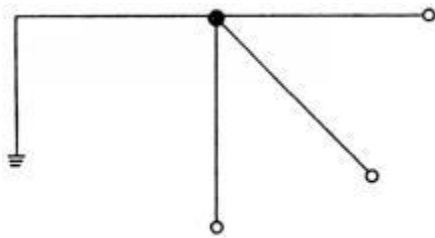

Fig. 20a

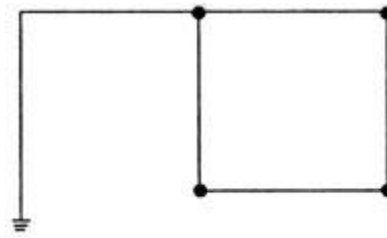

Fig. 20b

(4) High voltage filter is used. Adding a high-voltage filter to the high-voltage side of the secondary of the test transformer can further suppress the interference of the power grid system and improve the detection sensitivity. As shown in Fig. 21, the two-stage T-shaped filter can attenuate the 30kHz signal by 60dB if $L = 0.5\text{h}$ and $C = 0.004\text{f}$. Of course, the high voltage filter must also have no discharge under the test voltage. Domestic units have used the tuned frequency selective filter in series in the high voltage lead, and the effect is also very good.

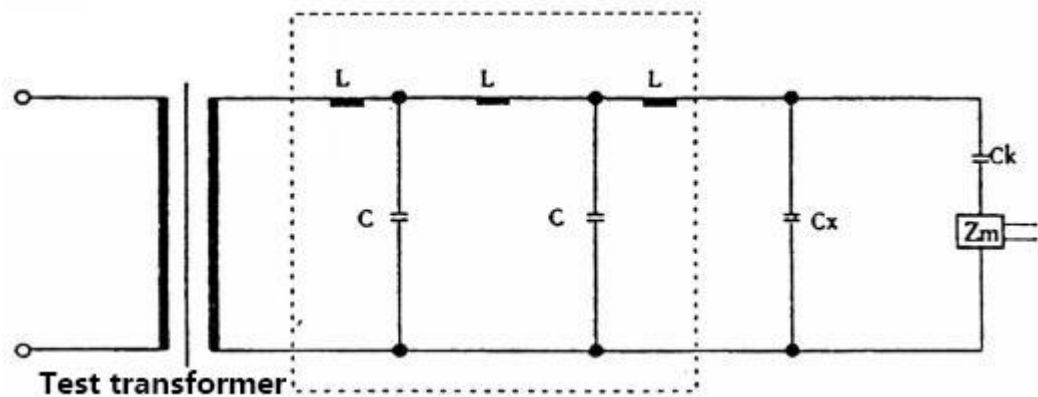

Fig. 21 High voltage filter connected to test circuit

In the figure, CX is the sample; CK is the coupling capacitance; ZM is the input unit.

(5) Balance method or bridge test circuit is used.

(6) By using the time window of the gate unit, the interference of the fixed phase does not fall into the "window".

(7) The amplifier adopts narrow frequency band, such as (40-80) kHz or avoiding the frequency range with large interference.

(8) Install high voltage shield or semi conductive rubber tire cap at high voltage end to prevent external corona interference.

(9) The test circuit is far away from surrounding objects, especially suspended metal

objects.

VII.Packing list

No.	Item	Qty
1	Power cord	1
2	Special measuring cable (standard configuration: 8m)	1

VIII.User selected equipment (Optional need extra money)

1. Input unit: no.1-12, suitable for 6pf-250 μ F test sample; in addition, 7R input unit can be selected for length measuring cable, optional;
2. High voltage resistance: 10kv-500kv voltage level, optional;
3. OWF series coupling capacitor: 10kv-500kv voltage level, 500-2000pf, optional;
4. Fof series voltage divider capacitor: 10kv-500kv voltage level, 500-2000pf, optional;
5. JZF series calibration pulse generator: jzf-6, jzf-9 and jzf-10, optional;
6. LB series power isolation filter;
7. YXY series power frequency high voltage test console;
8. Ywdt series power frequency no partial discharge test transformer: voltage class 10kv-500kv, capacity 1kva-500kva, optional.